



Door Control Board:

Board 104[®] for PM/SSC

© 2000, 1992 KONE Inc.

Unpublished work. All rights reserved. No portion of this volume may be used or reproduced in any manner without written permission from KONE Inc. — One KONE Ct; Moline, IL 61265

Due to our policy of continuing improvement, we reserve the right to alter design and specification without prior notice. The right to make changes to product design and material use, without notice, is reserved. All hardware and software referenced in this publication and/or used in conjunction with equipment described herein is the exclusive property of KONE Inc. whether or not protected by U.S. and/or International Trademark, Copyright and/or Patent Laws.

DOOR CONTROL BOARD:

Board 1Ø4® for PM/SSC

Equipment description	4
Features of door operators with Board 1Ø4®	4
Input & output terminals	5
Installing door operator control Board 1Ø4®	6
Adjusting door operator control Board 1Ø4®	8
Measure current (optional)	9
Set potentiometers	9
Adjust door speeds	10
Adjust door closing force	12
Adjust nudge speed	13
Set microswitch cams	14

Equipment description

Solid state door operators with Board 1Ø4® are described as follows.

- Features of door operators with Board 1Ø4®
- Input & output terminals

149-001 (8/2000)

FEATURES OF DOOR OPERATORS WITH BOARD 1Ø4®

Door operators with Board 1Ø4® control have following operations and features:

- Door control power
- Current control
- Speed & travel limits
- Acceleration & deceleration
- Troubleshooting & switch adjusting
- Auxiliary piloting
- Other features

Door control power. Door operator control uses a low voltage permanent magnet DC motor. DC motor is powered by pulse width modulated power (high speed switching - 20,000 Hz). Motor responds to average voltage of high frequency pulses, and not individual pulses.

Current control. Door operator control has a current sensing circuit in both open and closed directions to supply feedback to speed control circuit. Current sensing circuit regulates door closing force, and open/stall current caused by a hooked interlock. Current sensing circuit also guarantees that door operator control relay contacts do not break or make when motor armature current is present—helping to prevent damage to relay contacts. Motor direction is controlled by reversing armature connection using a conventional relay system.

Speed & travel limits. Door operator control selects speed and travel limits with cam operated microswitches. These microswitches operate relays tied into speed direction circuits.

Acceleration & deceleration. Door operator control has an internal soft-start circuit which regulates smooth acceleration and deceleration. Soft-start circuit allows average motor voltage to change gradually when speeds change.

Troubleshooting & adjusting switches. Door operator control has two small toggle switches mounted on common circuit board. TEST/RUN switch and

O-OFF-C switch are used to signal door opening or closing from car top during troubleshooting and adjusting; and to disconnect the door open and close signals, and de-activate internal shutdown timer.

Auxiliary piloting. Door operator control also has a Form “C” Open and a Form “C” Closed relay contact for auxiliary piloting.

Other features. Additional items added to Solid State door control.

- Non-adjustable open current limit set at 5 amps.
- Non-adjustable internal shutdown timer removes power if doors do not open or close within 20 to 30 seconds after a direction signal is given. Shutdown indicated by an illuminated LED 7.

F615-002 (3/97)

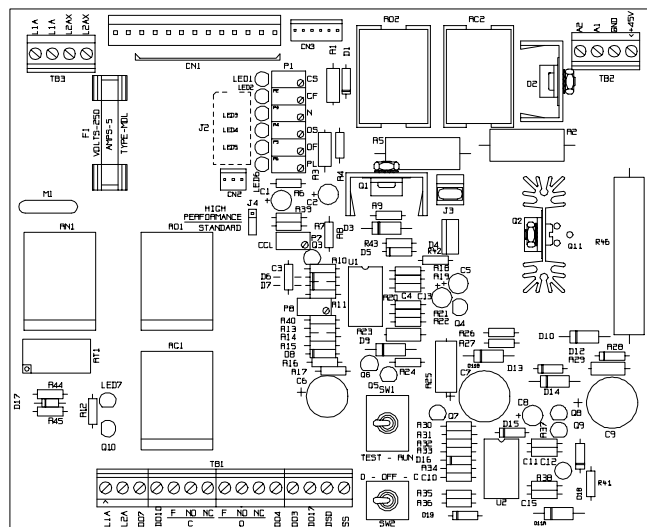

C202-H17(9/00)

Board 1Ø4®

INPUT & OUTPUT TERMINALS

The PM/SSC door operator control requires an input of single phase 115 VAC. When this power is supplied by a transformer, the transformer must have rating of at least 500 VA. Input and output terminal signals are connected to TB1 (3).

149-002 (8/2000)

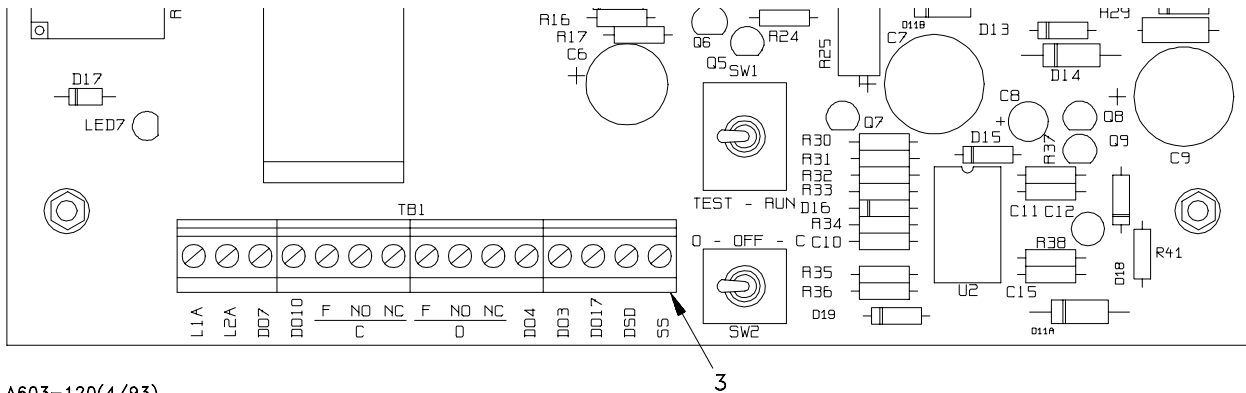

A603-120(4/93)

Input & Output Terminals

Required for door to operate

- L1A to L2A** **120VAC @ 500VA** input. If one of input lines is grounded, it should be connected to L1A.
- DO3 to L1A** **Open limit signal.** A relay across these terminals de-energizes when open limit microswitch is actuated. Relay is energized at all other times.
- DO7 to L1A** **Signal to close.** When a relay contact across these terminals makes up, doors should close.
- DO10 to L1A** **Signal to open.** When a relay contact across these terminals makes up, the doors should open.
- DO17 to L1A** **Close limit signal.** A relay across these terminals de-energizes when close limit microswitch is actuated. Relay is energized at all other times.

Optional

- DO3 to DO10** **Auxiliary to "O" relay.** A relay across these terminals should be energized only when doors are opening.
- DO7 to DO17** **Auxiliary to "C" relay.** A relay across these terminals should be energized only when doors are closing.
- DO4 to DO7** **Reduced speed closing signal.** When doors have a signal to close, and a relay contact across these terminals makes up, door speed is controlled by "N" potentiometer.
- F NC NO C** **Auxiliary C relay switching contact.** Designates a Form "C" contact on a 1-C relay.
- F NC NO O** **Auxiliary O relay switching contact.** Designates a Form "C" contact on 1-O relay.
- DSD to SS** **Optional -** Used on some projects for load balancing or other customer requirement.

F615-SI1 (3/97)

Installing door operator control Board 1Ø4®

The following describes replacing a three or four door control board with a single Door Control Board 1Ø4. Complete the following to install door operator control Board 1Ø4®.

When replacing a four-board system, a cable assembly (90527-022) must be used. This cable replaces the wires on the existing common board.

1. Turn OFF, lock-out, and tag mainline disconnect.
2. Disconnect the two transformer primary wires from the terminal strip on the common board.

High performance operators will have two wires in each terminal. Keep two-wire sets together so they can be replaced correctly on the new door control board. If the door operator is a high performance operator, the J4 jumper must be in the high performance position.

3. Unplug the molex connector.
 - This does not apply to four-board systems.
4. Remove 45 VDC supply wires and motor wires from power board.

Mark wires for correct polarity.

5. Remove wires connected to main terminal strip on common board.

Label each wire to indicate which terminal the wire will be connected to later.

6. Remove common board.
7. Replace styrofoam spacer with anti-static support spacer.
8. Install new Control Board 1Ø4®.
9. Connect wires previously removed from main terminal strip to new control board using labels to match each wire to correct terminal.

Door Control Board 1Ø4® does not require terminals on wire leads.

10. Connect 45 VDC supply to terminals +45V and GND of TB2.
 - Red wire is connected to +45V.
 - Black wire is connected to GND.
11. Connect motor wires to terminal A1 and A2 of TB2.

Reverse motor wires position as compared to original power board.

12. Plug molex connector into CN1.

Make sure wire number 1 of board molex is plugged into pin 1 of molex connector.

13. Connect transformer primary wires L2AX and L1A terminals of TB3.
 - Multiple terminals are furnished for connecting to HPM/SSC power supplies.

149-003 (9/2000)

Door Control Board: Board 1Ø4® for PM/SSC

Product Instruction

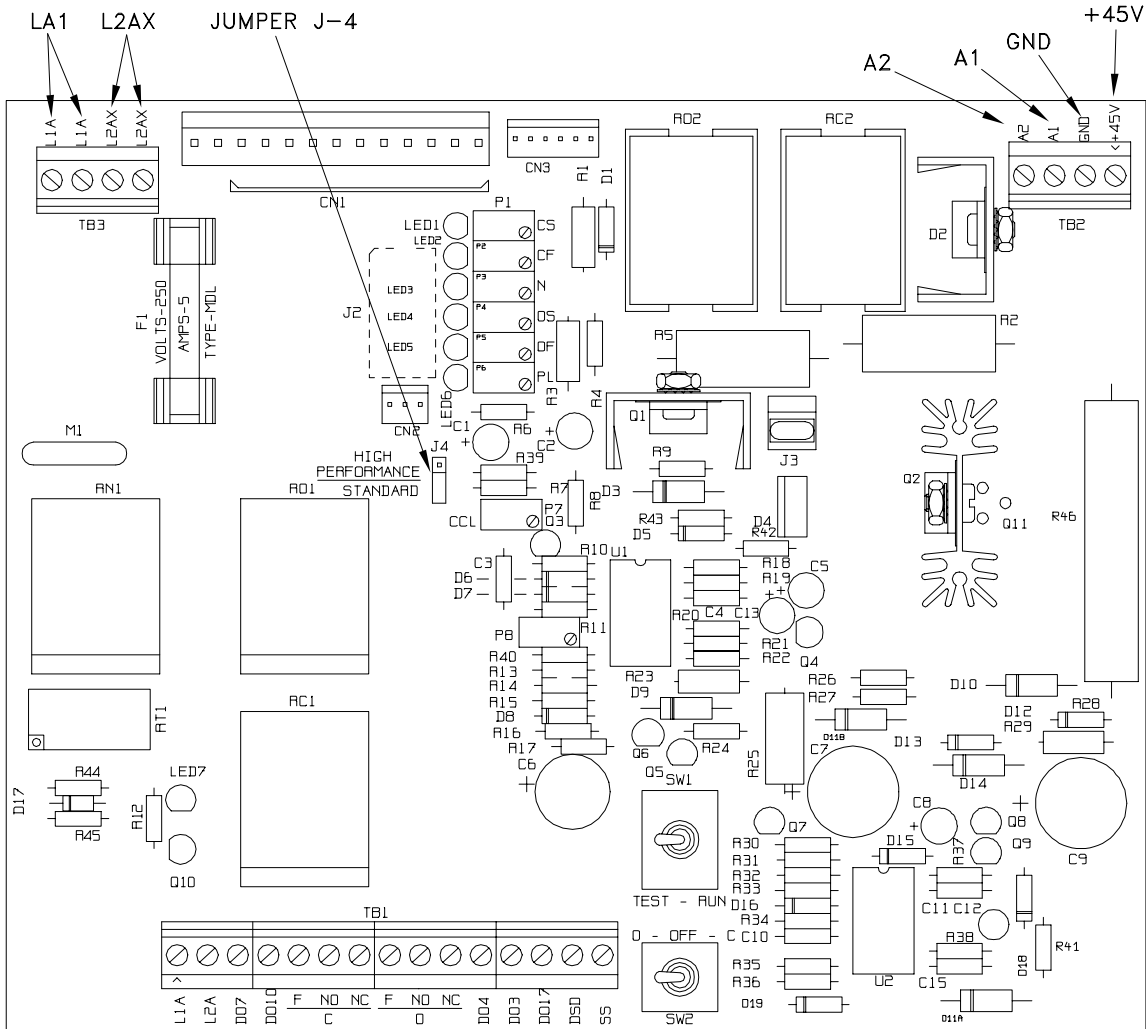

149-001(9/00)

Adjusting door operator control Board 1Ø4®

Adjust door operator control Board 1Ø4® as follows.

- Measure current (optional)
- Set potentiometers
- Adjust door speeds
- Adjust door closing force
- Adjust nudge speed
- Set microswitch cams

Board 1Ø4® could be damaged if adjustment instructions are not followed carefully. If you cannot complete any of procedures as described, stop and request assistance.

A604-017 (2/97)

Toggle switches

To adjust and service door control, use two toggle switches on door operator control Board 1Ø4® — TEST-RUN switch and O-OFF-C switch.

- **TEST-RUN.** TEST-RUN switch is normally in RUN position. When TEST-RUN switch is in TEST position, it disconnects normal open and close input signals from door control, and switches the O-OFF-C toggle switch into the circuit.
- **O-OFF-C.** O-OFF-C switch is normally in OFF (center) position. OFF position does not indicate input power has been removed. It only indicates no signal to open or close when TEST-RUN switch is in TEST position.

A604-S15 (2/97)

MEASURE CURRENT (OPTIONAL)

CAUTION: Do not install an ammeter in power supply line.

Current measurements are not required to adjust door operator control Board 1Ø4®. If necessary, measure current as follows.

1. Connect a voltmeter to resistor R2 (.1 Ohm 5 watt resistor) located between heat sinks Q2 and D2.

Viewing from TB1 side of control board, right side of resistor R2 is (-) and left side of resistor R2 is (+).

2. Set voltmeter to a low range — 1 volt or 2.5 volt.
3. Read measurement with following in mind.
 - 1 volt on meter indicates 10 amps of current.
 - .5 volt on meter indicates 5 amps of current.

A604-018 (2/97)

SET POTENTIOMETERS

Make sure all potentiometers are set to ZERO, except P8. *Do not set potentiometer P8.* It is factory-set and sealed.

These multi-turn potentiometers require 25 turns to traverse their complete range.

A604-019 (3/97)

ADJUST DOOR SPEEDS

1. Disconnect and tag-out power.
2. Remove door operator cover and close doors.
3. Set switches and potentiometer in following positions.
 - All speed control potentiometers - fully counter-clockwise.
 - C.C.L. potentiometer - Fully clockwise.
 - TEST-RUN switch - TEST position.
 - O-OFF-C switch - OFF (center) position.
 - Two position jumper J4 - just to right, and slightly above, R01 relay.
(*Standard* position if one pair of wires is present at TB3. *High Performance* if two pairs of wires are present at TB3.)
4. Apply power. Toggle O-OFF-C switch to “O” position. LED6 next to “PL” potentiometer illuminates, indicating doors are in PL zone.
5. Turn “PL” potentiometer clockwise until doors begin to open. When “PL” microswitch drops, LED next to “PL” potentiometer goes out, and LED next to “OF” potentiometer illuminates.
6. Turn “OF” potentiometer clockwise, just enough to move doors through “OF” speed zone. When “OSDL” microswitch drops, LED next to “OF” potentiometer goes out, and LED next to “OS” potentiometer illuminates.
7. Turn “OS” potentiometer, just enough to move door through “OS” speed zone. When “OL” cam activates “OL” microswitch, LED next to “OS” potentiometer goes out. Doors should be fully open.
8. Toggle O-OFF-C switch to C position. LED next to “CF” potentiometer comes on.
9. Turn “CF” potentiometer clockwise until doors begin to move. When “CSDL” microswitch is dropped by its cam, LED next to “CF” potentiometer goes out and LED next to “CS” potentiometer illuminates.
10. Turn “CS” potentiometer clockwise until “CL” microswitch is actuated by its CAM. LED next to “CS” potentiometer goes out. Doors should open and close at slow speed.
 - If doors do not fully open or close within 20 to 30 seconds, internal timer removes motor power and LED 7 is lit.
 - If board senses over 5 amps, power shuts down and LED 7 is lit.
11. Using speed zone potentiometer and CAM settings, adjust door speeds for desired performance. Green LED’s indicate which speed control potentiometer is controlling door speed.
 - **Increase door speed** — turn potentiometer *clockwise*
 - **Decrease door speed** — turn potentiometer *counterclockwise*

Do not set potentiometer P8. It is factory-set and sealed.

A604-020 (4/97)

TIP: If doors do not operate smoothly, particularly on slower moving doors, it may help to remove jumper J3. This eliminates dynamic braking, and allows a smoother transition between speeds.

A604-S16 (2/97)

Door Control Board: Board 104® for PM/SSC

Product Instruction

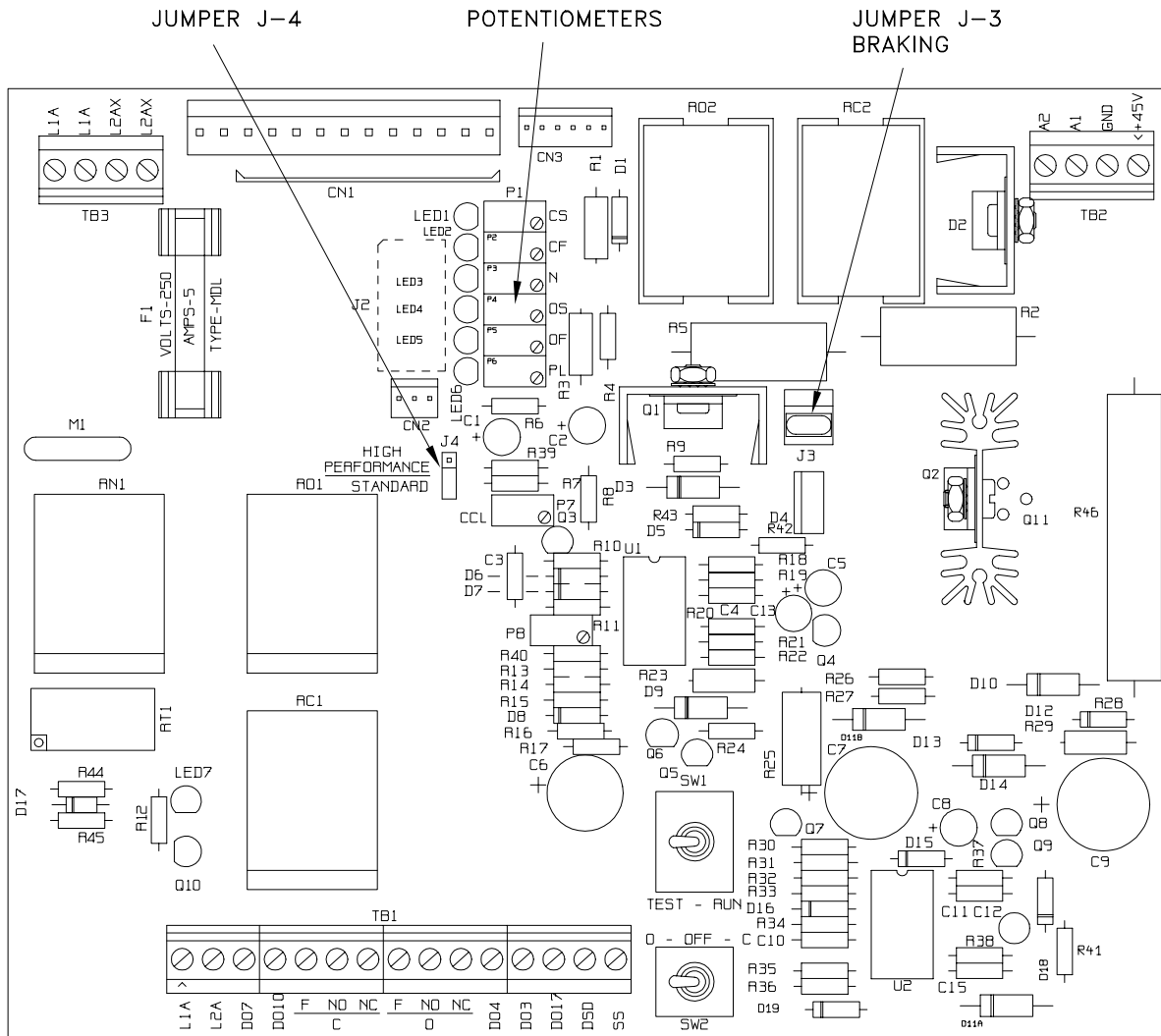

A603-121(9/00)

Board 104®

ADJUST DOOR CLOSING FORCE

1. Toggle TEST-RUN switch to TEST position.
2. Stop doors at mid-point in closing direction by toggling O-OFF-C switch to OFF position.
3. Turn CCL (close current limit) potentiometer fully counter-clockwise until doors stall.
4. Turn CCL potentiometer clockwise until desired door close operation is achieved. Door closing force should be less than 30 pound maximum allowed by Code.
5. To check door pressure, physically stall door at midpoint in closing direction.
6. Place rubber end of a pressure gauge (1) on edge of power-driven car door (3). Read pounds of force (2) on gauge and record results.
7. Open and close doors with O-OFF-C switch several times.
8. Physically stall doors again in closing direction and re-check door closing force with pressure gauge.

If door closing force CANNOT be kept under 30 pounds, contact the door factory.

A604-021 (9/2000)

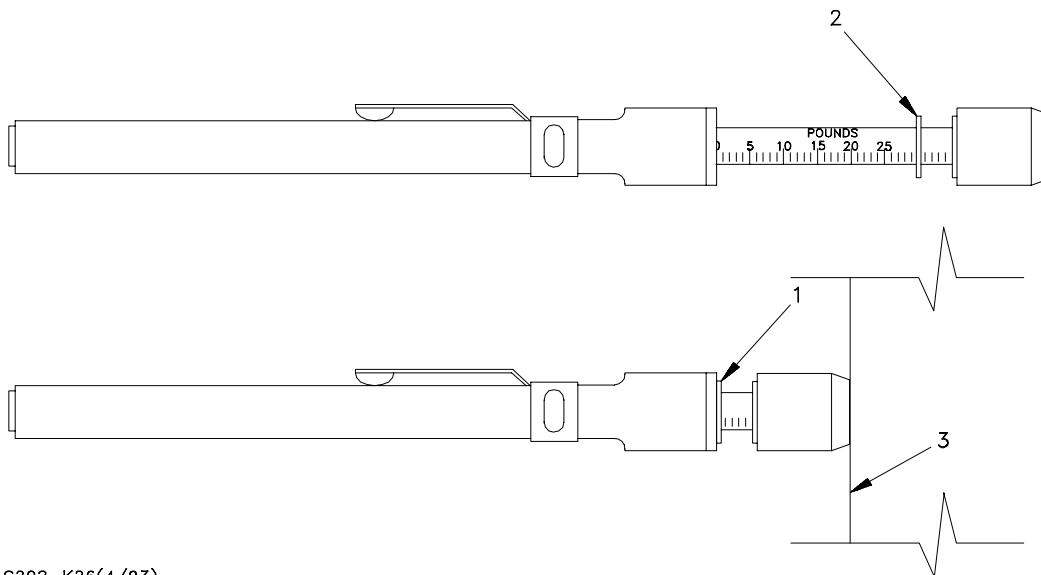

C202-K26(4/93)

ADJUST NUDGE SPEED

1. Simulate a nudge signal by placing a jumper on terminal strip TB-1 between L1A and DO4.
2. Set the TEST-RUN switch to TEST position.
3. Set O-OFF-C switch to C position. Doors should close at nudge speed.
4. Turn the N potentiometer clockwise to desired nudging speed.
5. Remove jumper between L1A and DO4 before returning the TEST-RUN switch to RUN.

F615-010 (2/97)

**When all adjustments are complete,
place O-OFF-C switch in OFF position,
and TEST-RUN switch in RUN position.
*Replace door operator cover.***

A604-S17 (2/97)

SET MICROSWITCH CAMS

PM/SSC door operator microswitch cams determine where changes in door speed occur. Factory settings are approximate. Set microswitch cams, if necessary, per individual job requirements.

CL CAM actuates CL microswitch when doors are in their desired fully closed position.

PL Initial opening CAM drops microswitch when car door clutch has just engaged both hoistway door rollers, but should not drop microswitch if door interlock hangs up.

OSDL CAM drops OSDL microswitch when doors are approximately half open.

CSDL CAM drops CSDL microswitch when doors are approximately 4 inches [10.2 mm] from their fully closed position.

OL CAM actuates OL microswitch when doors are in fully open position.

DSD (optional) CAM actuates DSD microswitch when doors are approximately 4 to 6 inches [10.2 to 15.2 mm] from fully closed position when used with load balancing. CAM can also be set for other customer requirements.

F615-009 (2/97)

- Wire Colors
- 1 = Black
 - 2 = Red
 - 3 = Yellow
 - 4 = Blue
 - 5 = Brown
 - 6 = Orange
 - 7 = Gray
 - 8 = Violet
 - 9 = White/Black
 - 10 = White/Red
 - 11 = White/Green
 - 12 = White/Yellow
 - 13 = White/Blue

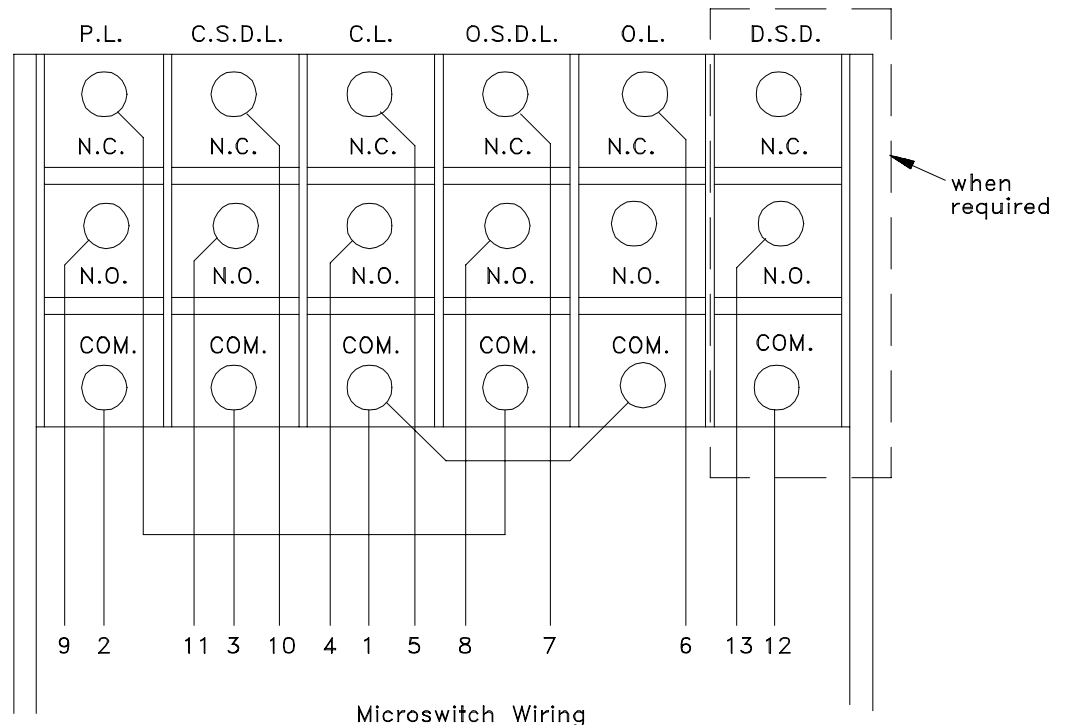

A603-124(4/93)

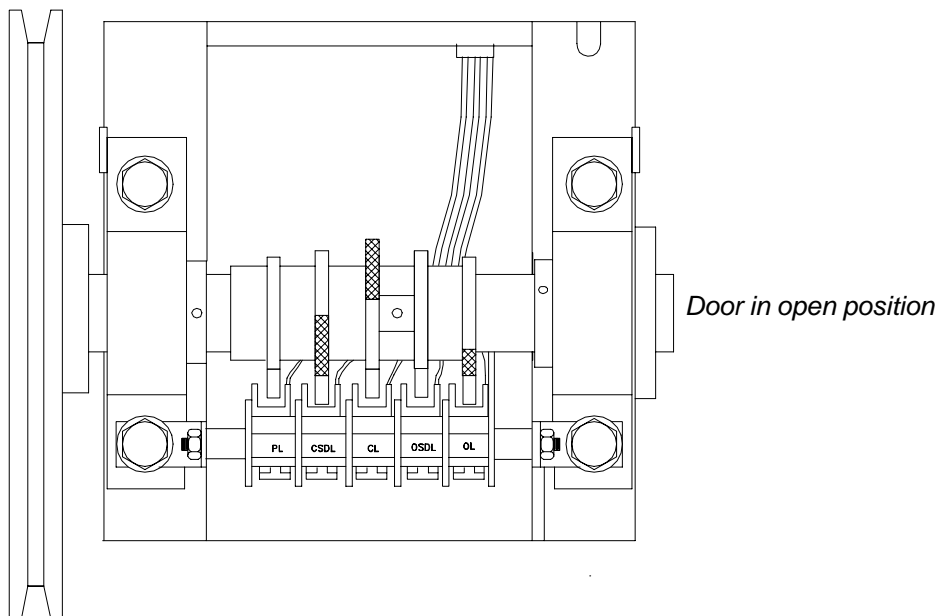
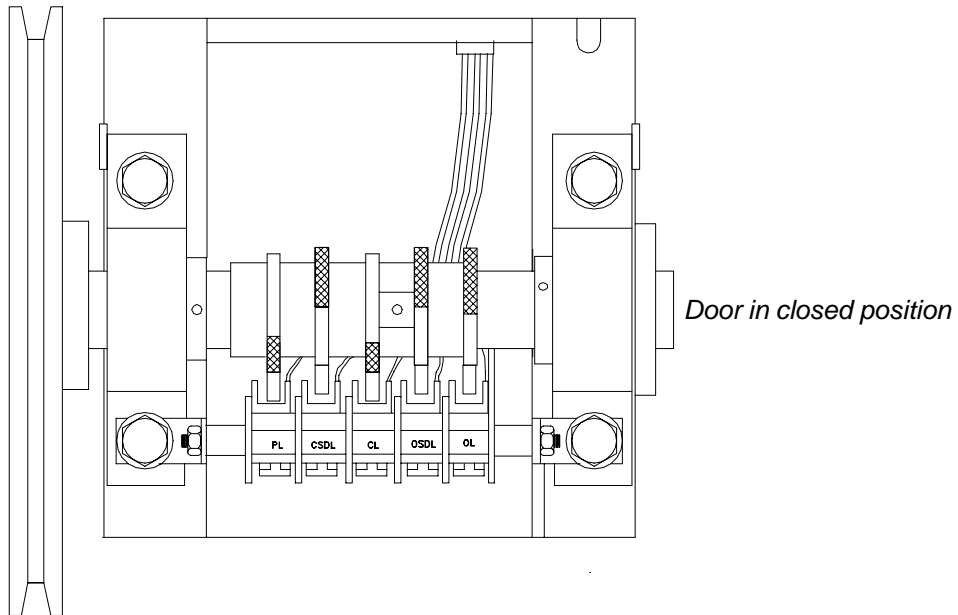

A603-122(4/93)

NOTES